

EXPERT

500
600

STONE SAWS

*Designed
and made
in Italy*

CONTROL BOARD

- Switch with release coil
- Overheat protection in the event of the disk jamming
- Mushroom-head push button to stop the machine
- Laser instrument for the maximum cutting precision (optional in standard version).

KIT WHEELS

The wheels are Ø220 mm and can be fixed at the legs by means eyebolts. Due to their conception and for the legs' inclination, are very functional and allow the machine to be easily moved if lightly lifted up by the handles.

STORAGE

Build to reduce at the maximum the encumbrance during the carriage and above all the storage space.

	Art. 9601	Art. 9600	Art. 9501	Art. 9500
DIAMOND DISK (not included)	Ø600 mm. (int Ø25,4 mm.)	Ø600 mm. (int Ø25,4 mm.)	Ø500 mm. (int Ø25,4 mm.)	Ø500 mm. (int Ø25,4 mm.)
ENGINE	400V 50Hz 5,5Hp/4kW	400V 50Hz 5,5Hp/4kW	400V 50Hz 5,5Hp/4kW	400V 50Hz 5,5Hp/4kW
ROTATION SPEED	1400 rpm.	1400 rpm.	1400 rpm.	1400 rpm.
AMPEROMETRICAL PROTECTION	10-16A	10-16A	10-16A	10-16A
MAX CUTTING LENGTH	750 mm.	750 mm.	750 mm.	750 mm.
MAX CUTTING DEPTH AT 90°	220 mm.	220 mm.	170 mm.	170 mm.
MAX CUTTING DEPTH WITH 2 RUNS	285 mm.	285 mm.	235 mm.	235 mm.
WORKING TABLE SIZE	520 x 443 mm.	520 x 443 mm.	520 x 443 mm.	520 x 443 mm.
WATER RECYCLING PUMP TYPE	S3 standard	S3 standard	S3 standard	S3 standard
KIT WHEELS	Standard	Optional	Standard	Optional
LASER INSTRUMENT	Standard	Optional	Standard	Optional
DIMENSION MACHINE IN SERVICE	720x1180x h. 1520 mm.	720x1180x h. 1520 mm.	720x1950x h. 1478 mm.	720x1950x h. 1478 mm.
DIMENSION MACHINE IN STOCK	800x1200x h. 1030 mm.	800x1200x h. 1030 mm.	800x1200x h. 1030 mm.	800x1200x h. 1030 mm.
DIMENSION 2 MACHINES ON PALLET	800x1200x h. 1800 mm.	800x1200x h. 1800 mm.	800x1200x h. 1800 mm.	800x1200x h. 1800 mm.
NET WEIGHT	85 Kg.	80 Kg.	85 Kg.	80 Kg.

AVAILABLE ALSO SINGLE PHASE: ENGINE 4,5 Hp | 3,5 kW

BATTIPAVTM

MACCHINE PER EDILIZIA | MACHINES FOR BUILDING

Z. i. 2 - Via Cavatorta, 6/1 | 48010 Cotignola (Ra) | ITALY
Tel. +39 0545 40004 | Fax +39 0545 41724
www.battipav.com | sales@battipav.com

AUTHORIZED DEALER:



February 2013



APPLICATION

Built to cut bricks, poroton blocks, marble blocks and all the different kind of materials for the building sector.

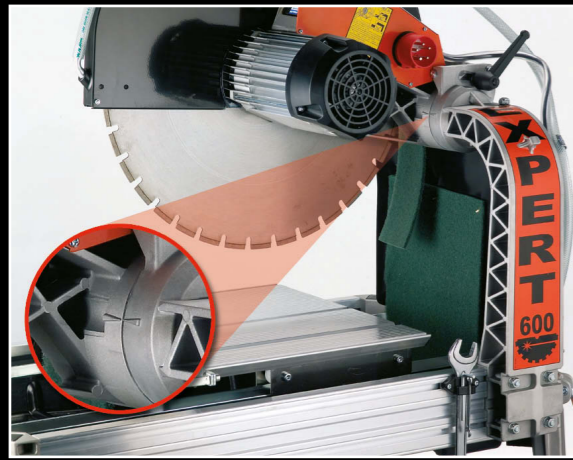

The cutting head and the arm are in die-casting aluminium to get the maximum of rigidity and lightness.
Quick reading indicator of the position for the cut in 2 RUNS.



An acoustic signal is activated when the phase is opposite to the direction of rotation of the diamond disk (Optional).

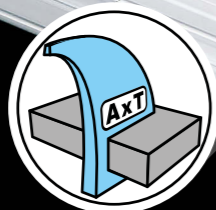

ORIGINAL RECYCLING PUMP



The cutting head is tilting and can be locked at the intended height.



The cutting position with sliding carriage.

LASER TRACER

- Connected directly to the net.
- Bulb with millimetrical adjustment of the ray in three space's directions.
- Lens with interchangeable protection glass.

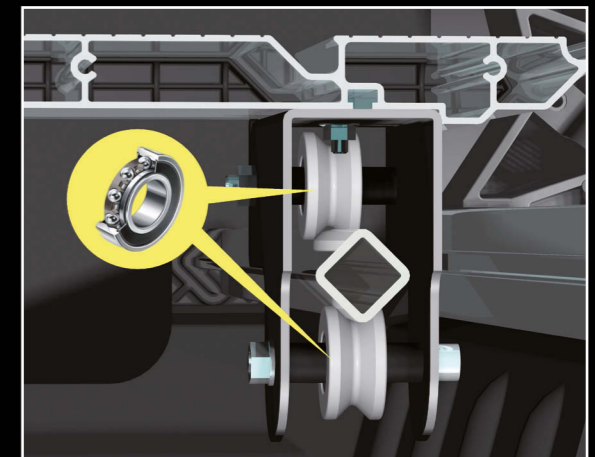

The working table is very strong and steady.

- It slides on 2 steel square rails with 6 wheels; 4 over and 2 under.
- Every wheel has 2 ball bearings for a total of 12.

